



## 18-BIT, 600-kHz, PSEUDO-DIFFERENTIAL INPUT, MICROPOWER SAMPLING ANALOG-TO-DIGITAL CONVERTER WITH SERIAL INTERFACE AND REFERENCE

### FEATURES

- 600-kHz Sample Rate
- $\pm 2$  LSB Typ,  $\pm 4$  LSB Max INL
- 18-Bit NMC Ensured Over Temperature
- SINAD 91 dB, SFDR 119 dB at  $f_i = 1$  kHz
- High-Speed Serial Interface up to 40 MHz
- Onboard Reference Buffer
- Onboard 4.096-V Reference
- Pseudo-Differential Input, 0 V to 4.2 V
- Onboard Conversion Clock
- Selectable Output Format, 2's Complement or Straight Binary
- Zero Latency
- Wide Digital Supply
- Low Power:
  - 115 mW at 600 kHz
  - 15 mW During Nap Mode
  - 10  $\mu$ W During Power Down
- 28-Pin 6 x 6 QFN Package

### APPLICATIONS

- Medical Instruments
- Optical Networking
- Transducer Interface
- High Accuracy Data Acquisition Systems
- Magnetometers

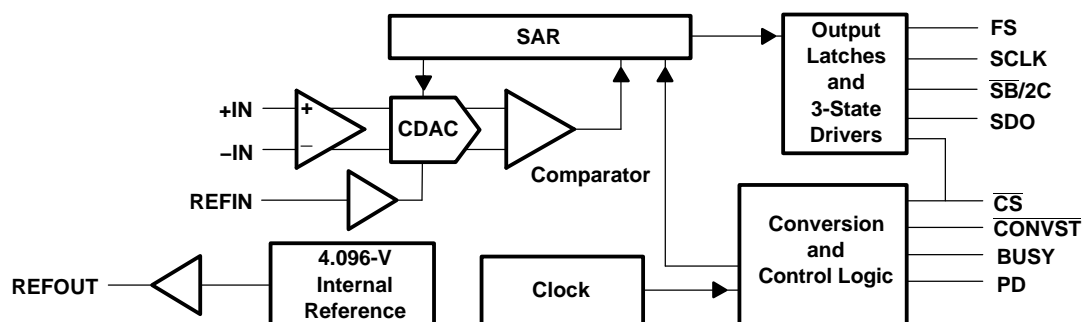
### DESCRIPTION

The ADS8380 is a high performance 18-bit, 600-kHz A/D converter with single-ended (pseudo-differential) input. The device includes an 18-bit capacitor-based SAR A/D converter with inherent sample and hold. The ADS8380 offers a high-speed CMOS serial interface with clock speeds up to 40 MHz.

The ADS8380 is available in a 28 lead 6 x 6 QFN package and is characterized over the industrial  $-40^{\circ}\text{C}$  to  $85^{\circ}\text{C}$  temperature range.

High Speed SAR Converter Family

Type/Speed	500 kHz	~ 600 kHz	750 kHz	1 MHz	1.25 MHz	2 MHz	3 MHz	4 MHz
18-Bit Pseudo-Diff	ADS8383	ADS8381						
		ADS8380 (S)						
18-Bit Pseudo-Bipolar, Fully Diff		ADS8382 (S)						
16-Bit Pseudo-Diff			ADS8371		ADS8401/05	ADS8411		
16-Bit Pseudo-Bipolar, Fully Diff					ADS8402/06	ADS8412		
14-Bit Pseudo-Diff					ADS7890 (S)		ADS7891	
12-Bit Pseudo-Diff				ADS7886				ADS7881



Please be aware that an important notice concerning availability, standard warranty, and use in critical applications of Texas Instruments semiconductor products and disclaimers thereto appears at the end of this data sheet.



These devices have limited built-in ESD protection. The leads should be shorted together or the device placed in conductive foam during storage or handling to prevent electrostatic damage to the MOS gates.

**ORDERING INFORMATION<sup>(1)</sup>**

MODEL	MAXIMUM INTEGRAL LINEARITY (LSB)	MAXIMUM DIFFERENTIAL LINEARITY (LSB)	NO MISSING CODES RESOLUTION (BIT)	PACKAGE TYPE	PACKAGE DESIGNATOR	TEMPERATURE RANGE	ORDERING INFORMATION	TRANSPORT MEDIA QUANTITY
ADS8380I	±6	-2/2.5	17	28 Pin 6×6 QFN	RHP	-40°C to 85°C	ADS8380IRHPT	Small Tape and reel 250
							ADS8380IRHPR	Tape and reel 1000
ADS8380IB	±4	-1/1.5	18	28 Pin 6×6 QFN	RHP	-40°C to 85°C	ADS8380IBRHPT	Small Tape and reel 250
							ADS8380IBRHPR	Tape and reel 1000

(1) For the most current specifications and package information, refer to our web site at [www.ti.com](http://www.ti.com)

**ABSOLUTE MAXIMUM RATINGS**

over operating free-air temperature range unless otherwise noted<sup>(1)</sup>

		UNIT
Voltage	+IN to AGND	-0.3 V to +VA + 0.3 V
	-IN to AGND	-0.3 V to +VA + 0.3 V
	+VA to AGND	-0.3 V to 7 V
	+VBD to BDGND	-0.3 V to 7 V
Digital input voltage to BDGND		-0.3 V to +VBD + 0.3 V
Digital input voltage to +VA		+0.3 V
Operating free-air temperature range, T <sub>A</sub>		-40°C to 85°C
Storage temperature range, T <sub>stg</sub>		-65°C to 150°C
Junction temperature (T <sub>J</sub> max)		150°C
QFN package	Power dissipation	(T <sub>Jmax</sub> - T <sub>A</sub> )/θ <sub>JA</sub>
	θ <sub>JA</sub> thermal impedance	86°C/W
Lead temperature, soldering	Vapor phase (60 sec)	215°C
	Infrared (15 sec)	220°C

(1) Stresses beyond those listed under "absolute maximum ratings" may cause permanent damage to the device. These are stress ratings only, and functional operation of the device at these or any other conditions beyond those indicated under "recommended operating conditions" is not implied. Exposure to absolute-maximum-rated conditions for extended periods may affect device reliability.

**SPECIFICATIONS**

At  $-40^{\circ}\text{C}$  to  $85^{\circ}\text{C}$ ,  $+V_A = +5\text{ V}$ ,  $+V_{BD} = +5\text{ V}$  or  $+V_{BD} = +2.7\text{ V}$ , using internal or external reference,  $f_{\text{SAMPLE}} = 600\text{ kHz}$ , unless otherwise noted. (All performance parameters are valid only after device has properly resumed from power down, see Table 2.)

PARAMETER	TEST CONDITIONS	ADS8380IB			ADS8380I			UNIT
		MIN	TYP	MAX	MIN	TYP	MAX	
<b>ANALOG INPUT</b>								
Full-scale input voltage <sup>(1)</sup>	+IN – (–IN)	0		$V_{\text{ref}}$	0		$V_{\text{ref}}$	V
Absolute input voltage	+IN	–0.2		$V_{\text{ref}} + 0.2$	–0.2		$V_{\text{ref}} + 0.2$	V
	–IN	–0.2		0.2	–0.2		0.2	
Sampling capacitance (measured from $\pm\text{IN}$ to AGND)			40			40		pF
Input leakage current			1			1		nA
<b>SYSTEM PERFORMANCE</b>								
Resolution			18			18		Bits
No missing codes		18			17			Bits
INL Integral linearity <sup>(2)(3)(4)</sup>	Quiet zones observed	–4	$\pm 2$	4	–6		6	LSB (18 bit)
	Quiet zones not observed		$\pm 2.75$					
DNL Differential linearity <sup>(3)</sup>	Quiet zones observed	–1	$\pm 0.75$	1.5	–2		2.5	LSB (18 bit)
	Quiet zones not observed		$\pm 1.5$					
$E_O$ Offset error <sup>(3)</sup>		–0.75	$\pm 0.4$	0.75	–1.5		1.5	mV
$E_G$ Gain error <sup>(3)(5)</sup>		–0.075		0.075	–0.1		0.1	%FS
CMRR Common-mode rejection ratio	At DC		80			80		dB
	$[\text{+IN} - (-\text{IN})] = V_{\text{ref}}/2$ with 50 mV <sub>p-p</sub> common mode signal at 1 MHz		55			55		
Noise	At 0 V analog input		40			40		$\mu\text{V RMS}$
PSRR DC Power supply rejection ratio	At full scale analog input		55			55		dB
<b>SAMPLING DYNAMICS</b>								
Conversion time				1.16			1.16	$\mu\text{s}$
Acquisition time		0.50		1000	0.50		1000	$\mu\text{s}$
Throughput rate				600			600	kHz
Aperture delay			10			10		ns
Aperture jitter			12			12		ps RMS
Step response	<sup>(6)</sup>		400			400		ns
Overvoltage recovery			400			400		ns

- (1) Ideal input span; does not include gain or offset error.
- (2) LSB means least significant bit.
- (3) Measured using analog input circuit in Figure 51 and digital stimulus in Figure 56 and Figure 57 and reference voltage of 4.096 V.
- (4) This is endpoint INL, not best fit.
- (5) Measured using external reference source so does not include internal reference voltage error or drift.
- (6) Defined as sampling time necessary to settle an initial error of  $V_{\text{ref}}$  on the sampling capacitor to a final error of 1 LSB at 18-bit level. Measured using the input circuit in Figure 51.

PARAMETER	TEST CONDITIONS	ADS8380IB			ADS8380I			UNIT	
		MIN	TYP	MAX	MIN	TYP	MAX		
<b>DYNAMIC CHARACTERISTICS</b>									
THD	Total harmonic distortion <sup>(7)(8)</sup>	VIN = 4 V <sub>p-p</sub> at 1 kHz		-112		-112		dB	
		VIN = 4 V <sub>p-p</sub> at 10 kHz		-112		-112			
		VIN = 4 V <sub>p-p</sub> at 100 kHz		-92		-92			
SNR	Signal-to-noise ratio <sup>(7)</sup>	VIN = 4 V <sub>p-p</sub> at 1 kHz		91		91		dB	
		VIN = 4 V <sub>p-p</sub> at 10 kHz		91		91			
		VIN = 4 V <sub>p-p</sub> at 100 kHz		89.5		89.5			
SINAD	Signal-to-noise + distortion <sup>(7)(8)</sup>	VIN = 4 V <sub>p-p</sub> at 1 kHz		91		91		dB	
		VIN = 4 V <sub>p-p</sub> at 10 kHz		91		91			
		VIN = 4 V <sub>p-p</sub> at 100 kHz		87.5		87.5			
SFDR	Spurious free dynamic range <sup>(7)</sup>	VIN = 4 V <sub>p-p</sub> at 1 kHz		119		119		dB	
		VIN = 4 V <sub>p-p</sub> at 10 kHz		117		117			
		VIN = 4 V <sub>p-p</sub> at 100 kHz		92		92			
	-3dB Small signal bandwidth			75		75		MHz	
<b>REFERENCE INPUT</b>									
V <sub>ref</sub>	Reference voltage input range		2.5	4.096	4.2	2.5	4.096	4.2	V
	Resistance <sup>(9)</sup>		10			10			MΩ
<b>INTERNAL REFERENCE OUTPUT</b>									
V <sub>ref</sub>	Reference voltage range	IOUT = 0 A, T <sub>A</sub> = 30°C	4.088	4.096	4.104	4.088	4.096	4.104	V
	Source current	Static load	10			10			μA
	Line regulation	+VA = 4.75 V to 5.25 V	2.5			2.5			mV
	Drift	IOUT = 0 A	25			25			ppm/°C
<b>DIGITAL INPUT/OUTPUT</b>									
Logic family CMOS									
V <sub>IH</sub>	High level input voltage		+VBD - 1	+VBD + 0.3	+VBD - 1	+VBD + 0.3		V	
V <sub>IL</sub>	Low level input voltage		-0.3	0.8	-0.3	0.8		V	
V <sub>OH</sub>	High level output voltage	I <sub>OH</sub> = 2 TTL loads	+VBD - 0.6			+VBD - 0.6			V
V <sub>OL</sub>	Low level output voltage	I <sub>OL</sub> = 2 TTL loads	0.4			0.4			V
Data format: MSB first, 2's complement or straight binary (selectable via the $\overline{SB}/2C$ pin)									
<b>POWER SUPPLY REQUIREMENTS</b>									
Power supply voltage	+VA		4.75	5	5.25	4.75	5	5.25	V
	+VBD		2.7	3.3	5.25	2.7	3.3	5.25	V
I <sub>CC</sub>	Supply current, 600-kHz sample rate <sup>(10)</sup>	+VA = 5 V		22	25		22	25	mA
<b>POWER DOWN</b>									
I <sub>CC(PD)</sub>	Supply current, power down			2			2		μA
<b>NAP MODE</b>									
I <sub>CC(NAP)</sub>	Supply current, nap mode			3			3		mA
	Power-up time from nap			300			300		ns
<b>TEMPERATURE RANGE</b>									
	Specified performance		-40		85	-40		85	°C

(7) Measured using analog input circuit in Figure 51 and digital stimulus in Figure 56 and Figure 57 and reference voltage of 4.096 V.

(8) Calculated on the first nine harmonics of the input frequency.

(9) Can vary +/-30%.

(10) This includes only +VA current. With +VBD = 5 V, +VBD current is typically 1 mA with a 10-pF load capacitance on the digital output pins.

**TIMING REQUIREMENTS**<sup>(1)(2)(3)(4)(5)(6)</sup>

PARAMETER		ADS8380I/ADS8380IB			UNIT	REF FIGURE
		MIN	TYP	MAX		
t <sub>conv</sub>	Conversion time	1000		1160	ns	41 – 44
t <sub>acq1</sub>	Acquisition time in normal mode	0.5		1000	μs	41,42,44
t <sub>acq2</sub>	Acquisition time in nap mode (t <sub>acq2</sub> = t <sub>acq1</sub> + t <sub>d18</sub> )	0.8		1000	μs	43
<b>CONVERSION AND SAMPLING</b>						
t <sub>quiet1</sub>	Quiet sampling time (last toggle of interface signals to convert start command) <sup>(6)</sup>	30			ns	40 – 43, 45 – 47
t <sub>quiet2</sub>	Quiet sampling time (convert start command to first toggle of interface signals) <sup>(6)</sup>	10			ns	40 – 43, 45 – 47
t <sub>quiet3</sub>	Quiet conversion time (last toggle of interface signals to fall of BUSY) <sup>(6)</sup>	600			ns	40 – 43, 45,47
t <sub>su1</sub>	Setup time, $\overline{\text{CONVST}}$ before BUSY fall	15			ns	41
t <sub>su2</sub>	Setup time, $\overline{\text{CS}}$ before BUSY fall (only for conversion/sampling control)	20			ns	40,41
t <sub>su4</sub>	Setup time, $\overline{\text{CONVST}}$ before $\overline{\text{CS}}$ rise (so $\overline{\text{CONVST}}$ can be recognized)	5			ns	41,43,44
t <sub>h1</sub>	Hold time, $\overline{\text{CS}}$ after BUSY fall (only for conversion/sampling control)	0			ns	41
t <sub>h3</sub>	Hold time, $\overline{\text{CONVST}}$ after $\overline{\text{CS}}$ rise	7			ns	43
t <sub>h4</sub>	Hold time, $\overline{\text{CONVST}}$ after $\overline{\text{CS}}$ fall (to ensure width of $\overline{\text{CONVST\_QUAL}}$ ) <sup>(4)</sup>	20			ns	42
t <sub>w1</sub>	$\overline{\text{CONVST}}$ pulse duration	20			ns	43
t <sub>w2</sub>	$\overline{\text{CS}}$ pulse duration	10			ns	41,42
t <sub>w5</sub>	Pulse duration, time between conversion start command and conversion abort command to successfully abort the ongoing conversion			1000	ns	44
<b>DATA READ OPERATION</b>						
t <sub>cyc</sub>	SCLK period	25			ns	45 – 47
	SCLK duty cycle	40%		60%		
t <sub>su5</sub>	Setup time, $\overline{\text{CS}}$ fall before first SCLK fall	10			ns	45
t <sub>su6</sub>	Setup time, $\overline{\text{CS}}$ fall before FS rise	7			ns	46,47
t <sub>su7</sub>	Setup time, FS fall before first SCLK fall	7			ns	46,47
t <sub>h5</sub>	Hold time, $\overline{\text{CS}}$ fall after SCLK fall	3			ns	45
t <sub>h6</sub>	Hold time, FS fall after SCLK fall	7			ns	46,47
t <sub>su2</sub>	Setup time, $\overline{\text{CS}}$ fall before BUSY fall (only for read control)	20			ns	40,45
t <sub>su3</sub>	Setup time, FS fall before BUSY fall (only for read control)	20			ns	40,47
t <sub>h2</sub>	Hold time, $\overline{\text{CS}}$ fall after BUSY fall (only for read control)	15			ns	40,45
t <sub>h8</sub>	Hold time, FS fall after BUSY fall (only for read control)	15			ns	40,47
t <sub>w2</sub>	$\overline{\text{CS}}$ pulse duration	10			ns	45
t <sub>w3</sub>	FS pulse duration	10			ns	46,47
<b>MISCELLANEOUS</b>						
t <sub>w4</sub>	PD pulse duration for reset and power down	60			ns	53,54
	All unspecified pulse durations	10			ns	

- (1) All input signals are specified with t<sub>r</sub> = t<sub>f</sub> = 5 ns (10% to 90% of V<sub>DD</sub>) and timed from a voltage level of (V<sub>IL</sub> + V<sub>IH</sub>)/2.
- (2) All specifications typical at –40°C to 85°C, +VA = +4.75 V to +5.25 V, +VBD = +2.7 V to +5.25 V.
- (3) All digital output signals loaded with 10-pF capacitors.
- (4)  $\overline{\text{CONVST\_QUAL}}$  is  $\overline{\text{CONVST}}$  latched by a low value on  $\overline{\text{CS}}$  (see Figure 39).
- (5) Reference figure indicated is only a representative of where the timing is applicable and is not exhaustive.
- (6) Quiet time zones are for meeting performance and not functionality.

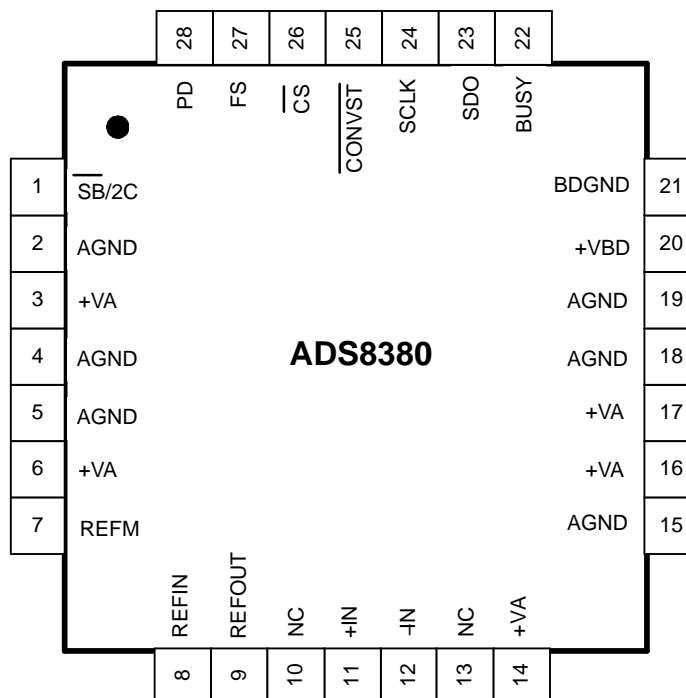
**TIMING CHARACTERISTICS**<sup>(1)(2)(3)(4)</sup>

PARAMETER		ADS8380I/ADS8380IB			UNIT	REF FIGURE
		MIN	TYP	MAX		
<b>CONVERSION AND SAMPLING</b>						
t <sub>d1</sub>	Delay time, conversion start command to conversion start (aperture delay)			10	ns	41,43
t <sub>d2</sub>	Delay time, conversion end to BUSY fall			5	ns	41 – 43
t <sub>d4</sub>	Delay time, conversion start command to BUSY rise			20	ns	41
t <sub>d3</sub>	Delay time, $\overline{\text{CONVST}}$ rise to sample start			5	ns	43
t <sub>d5</sub>	Delay time, $\overline{\text{CS}}$ fall to sample start			10	ns	43
t <sub>d6</sub>	Delay time, conversion abort command to BUSY fall			10	ns	44
<b>DATA READ OPERATION</b>						
t <sub>d12</sub>	Delay time, $\overline{\text{CS}}$ fall to MSB valid	3		15	ns	45
t <sub>d15</sub>	Delay time, FS rise to MSB valid	6		18	ns	46,47
t <sub>d7</sub>	Delay time, BUSY fall to MSB valid (if FS is high when BUSY falls)			18	ns	47
t <sub>d13</sub>	Delay time, SCLK rise to bit valid	2		10	ns	45– 47
t <sub>d14</sub>	Delay time, $\overline{\text{CS}}$ rise to SDO 3-state			6	ns	45
<b>MISCELLANEOUS</b>						
t <sub>d10</sub>	Delay time, PD rise to SDO 3-state			55	ns	53,54
t <sub>d18</sub>	Delay time, total device resume time	Nap mode		300	ns	55
		Full power down (external reference used with or without 1- $\mu$ F  0.1- $\mu$ F capacitor on REFOUT)		t <sub>d11</sub> + 2x conversions		54
		Full power down (internal reference used with or without 1- $\mu$ F  0.1- $\mu$ F capacitor on REFOUT)		25 <sup>(4)</sup>	ms	53
t <sub>d11</sub>	Delay time, untrimmed circuit full power-down resume time			1	ms	53,54
t <sub>d16</sub>	Delay time, device power-down time	Nap		200	ns	55
		Full power down (internal/external reference used)		10	$\mu$ s	53,54
t <sub>d17</sub>	Delay time, trimmed internal reference settling (either by turning on supply or resuming from full power-down mode), with 1- $\mu$ F  0.1- $\mu$ F capacitor on REFOUT			4	ms	53

- (1) All input signals are specified with t<sub>r</sub> = t<sub>f</sub> = 5 ns (10% to 90% of V<sub>DD</sub>) and timed from a voltage level of (V<sub>IL</sub> + V<sub>IH</sub>)/2.
- (2) All specifications typical at –40°C to 85°C, +VA = +4.75 V to +5.25 V, +VBD = +2.7 V to +5.25 V.
- (3) All digital output signals loaded with 10-pF capacitors.
- (4) Including t<sub>d11</sub>, two conversions (time to cycle CONVST twice), and t<sub>d17</sub>.

**PIN ASSIGNMENTS**

**TOP VIEW**



**TERMINAL FUNCTIONS**

PIN		I/O	DESCRIPTION
NAME	NO.		
AGND	2, 4, 5, 15, 18, 19	–	Analog ground pins. AGND must be shorted to analog ground plane below the device.
BDGND	21	–	Digital ground for all digital inputs and outputs. BDGND must be shorted to the analog ground plane below the device.
BUSY	22	O	Status output. This pin is high when conversion is in progress.
CONVST	25	I	Convert start. This signal is qualified with CS internally.
CS	26	I	Chip select
FS	27	I	Frame sync. This signal is qualified with CS internally.
+IN	11	I	Noninverting analog input channel
-IN	12	I	Inverting analog input channel
NC	10, 13	–	No connection
PD	28	I	Power down. Device resets and powers down when this signal is high.
REFIN	8	I	Reference (positive) input. REFIN must be decoupled with REFM pin using 0.1-μF bypass capacitor and 1-μF storage capacitor.
REFM	7	I	Reference ground. To be connected to analog ground plane.
REFOUT	9	O	Internal reference output. Shorted to REFIN pin only when internal reference is used.
SB/2C	1	I	Straight binary or 2's complement output data format. When low the device output is straight binary format; when high the device output is 2's complement format. See Table 1.
SCLK	24	I	Serial clock. Data is shifted onto SDO with the rising edge of this clock. This signal is qualified with CS internally.
SDO	23	O	Serial data out. All bits except MSB are shifted out at the rising edge of SCLK.
+VA	3, 6, 14, 16, 17	–	Analog power supplies
+VBD	20	–	Digital power supply for all digital inputs and outputs.

**TYPICAL CHARACTERISTICS**

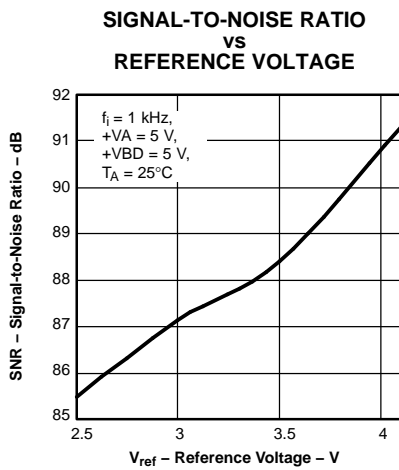


Figure 1.

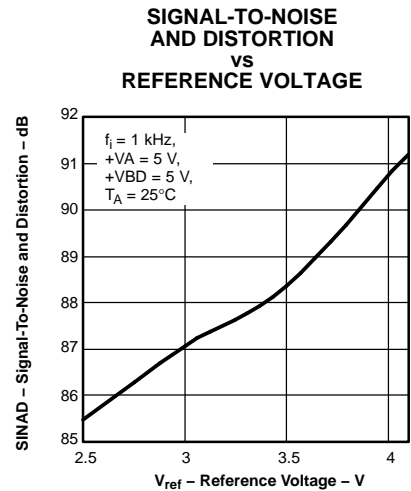


Figure 2.

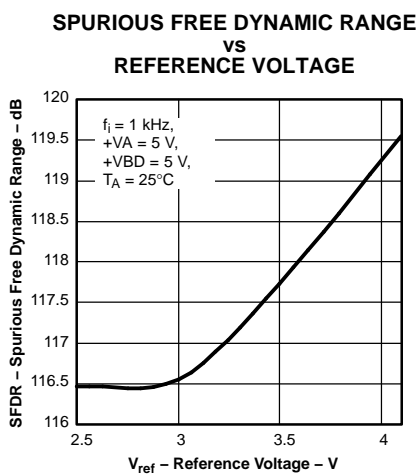


Figure 3.

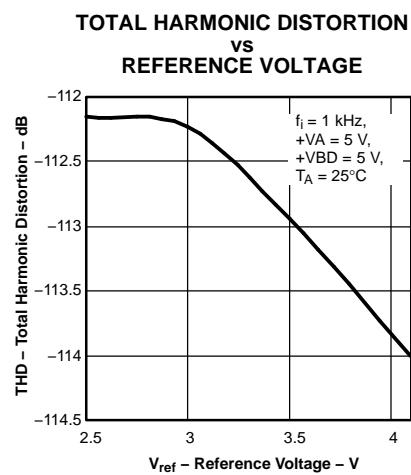


Figure 4.

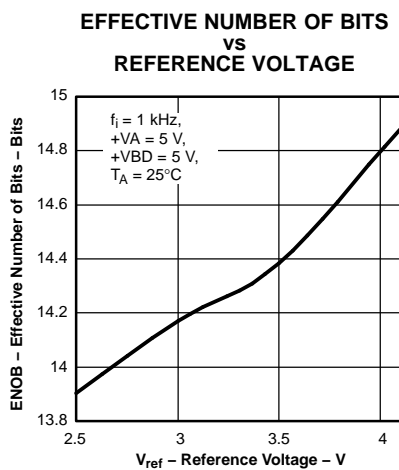


Figure 5.

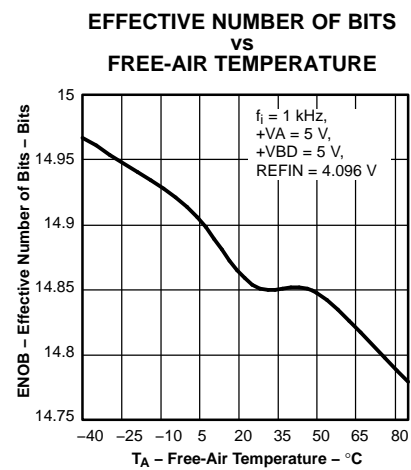


Figure 6.

**TYPICAL CHARACTERISTICS (continued)**

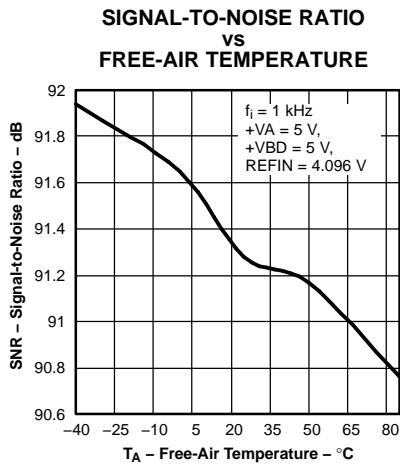


Figure 7.

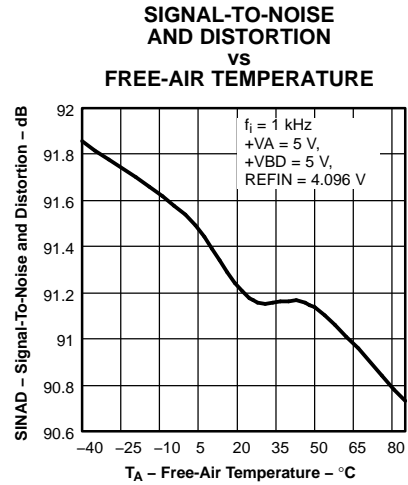


Figure 8.

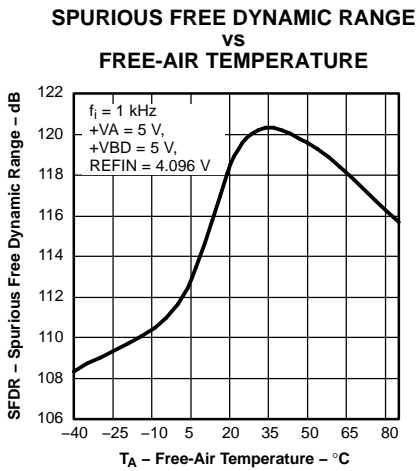


Figure 9.

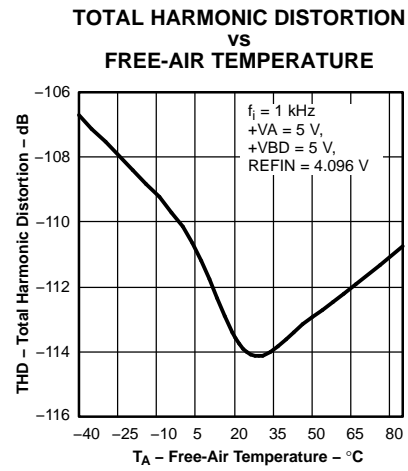


Figure 10.

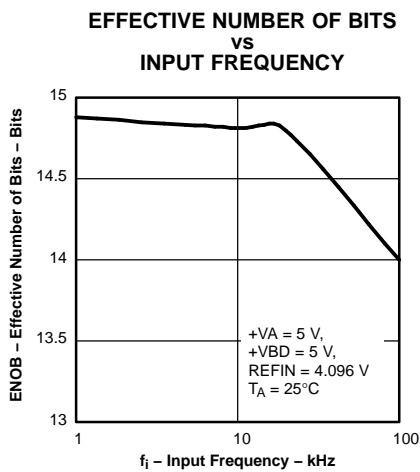


Figure 11.

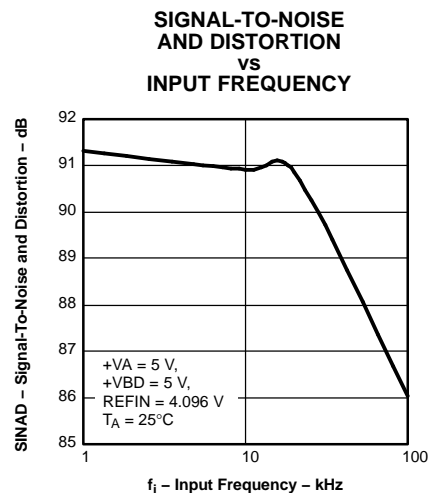


Figure 12.

TYPICAL CHARACTERISTICS (continued)

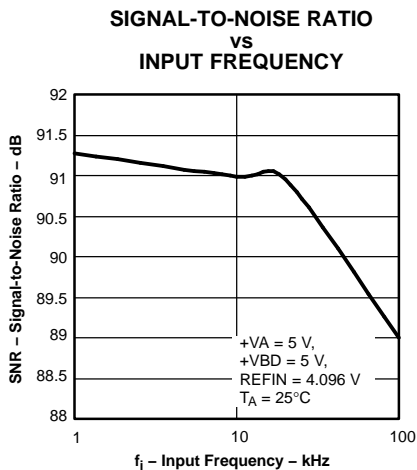


Figure 13.

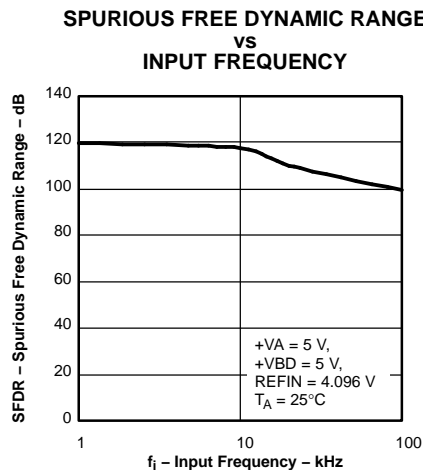


Figure 14.

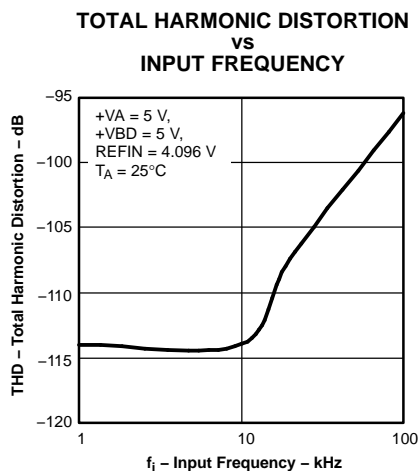


Figure 15.

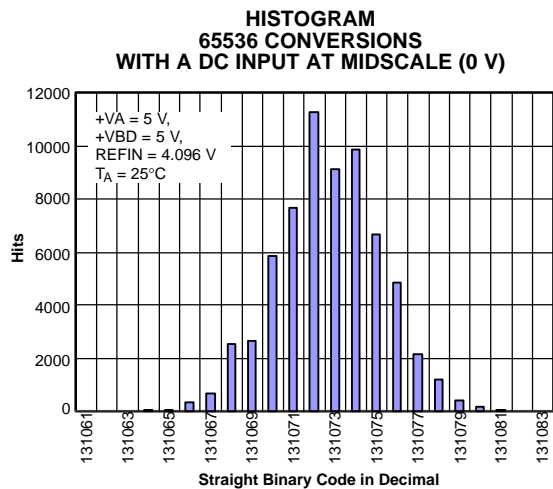


Figure 16.

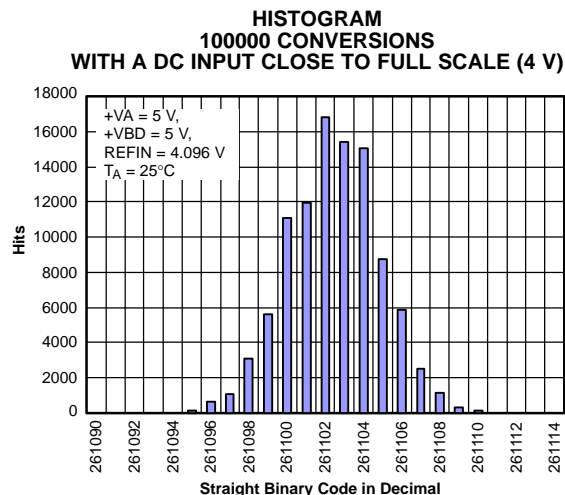
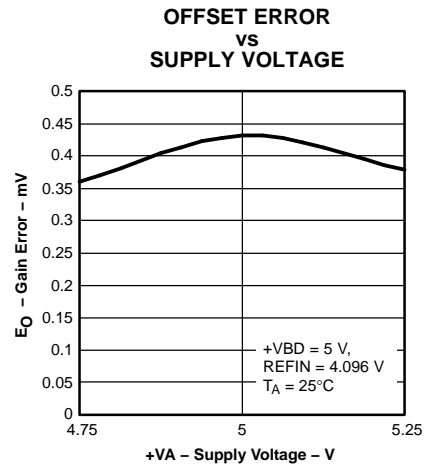
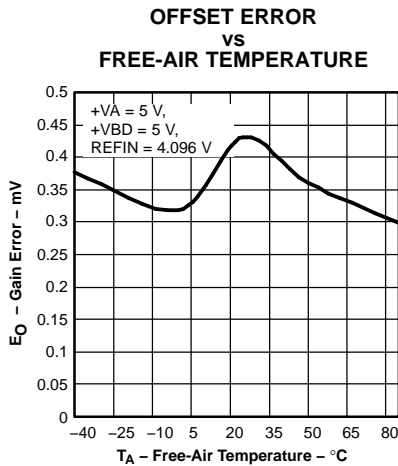
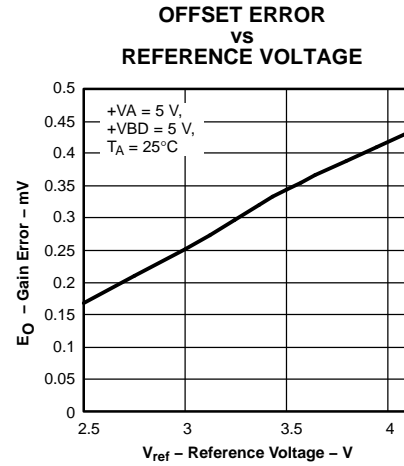
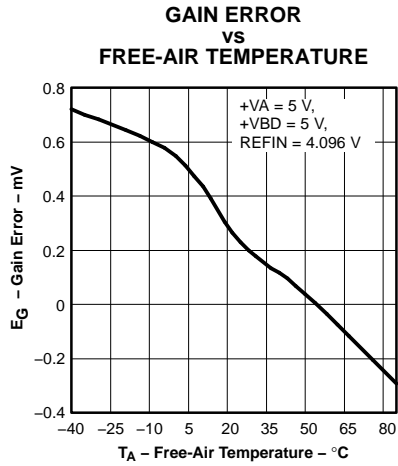
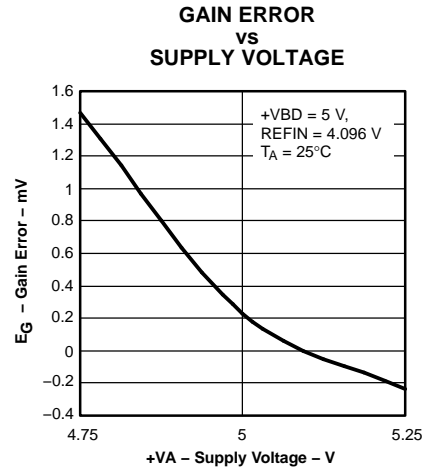
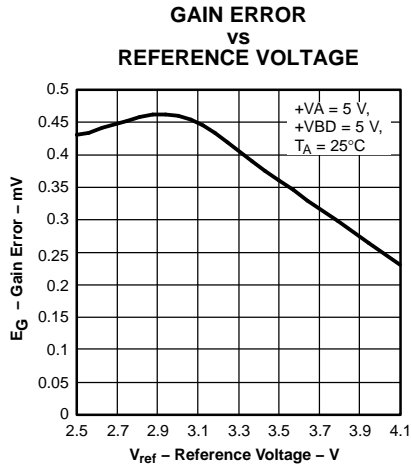


Figure 17.

**TYPICAL CHARACTERISTICS (continued)**



TYPICAL CHARACTERISTICS (continued)

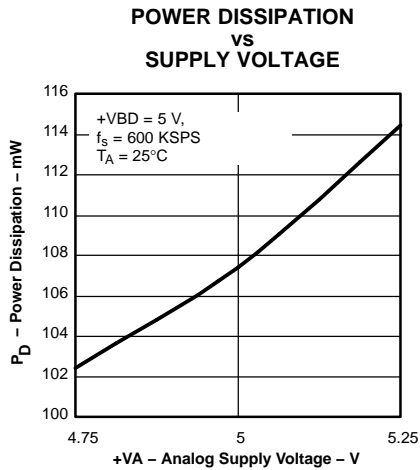


Figure 24.

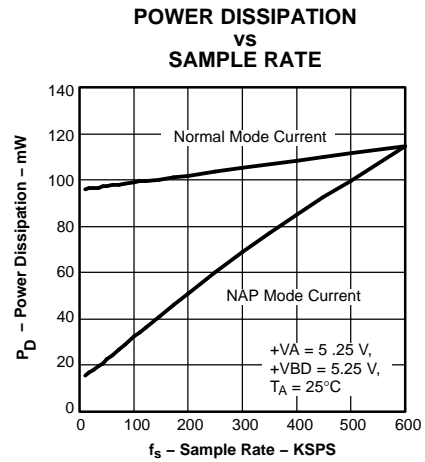


Figure 25.

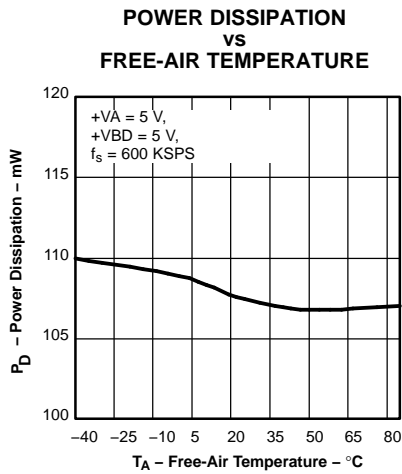


Figure 26.

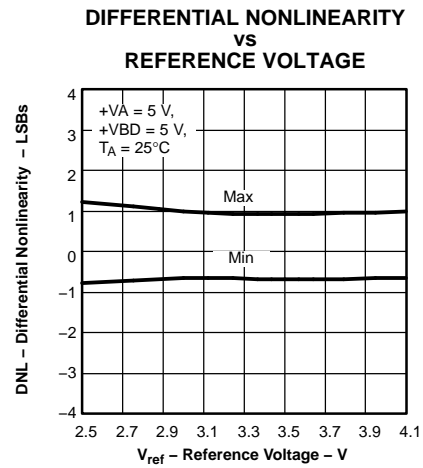


Figure 27.

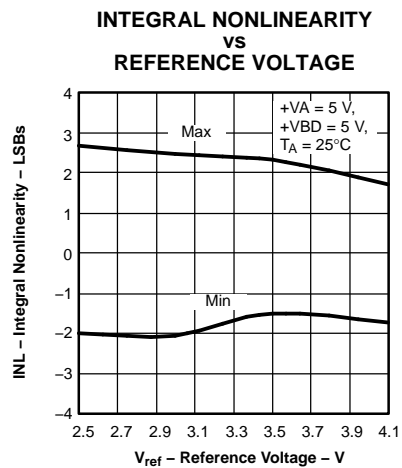


Figure 28.

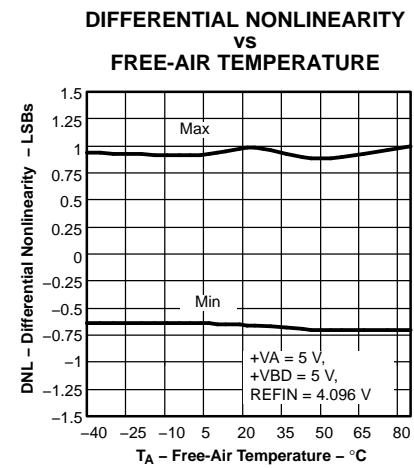


Figure 29.

**TYPICAL CHARACTERISTICS (continued)**

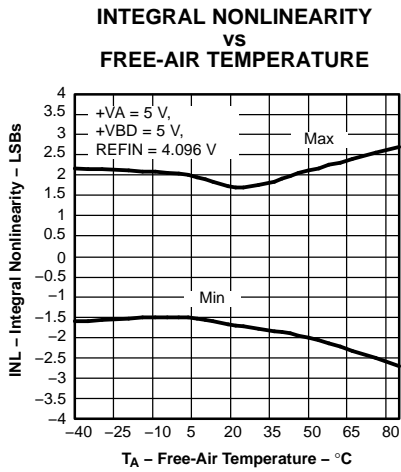


Figure 30.

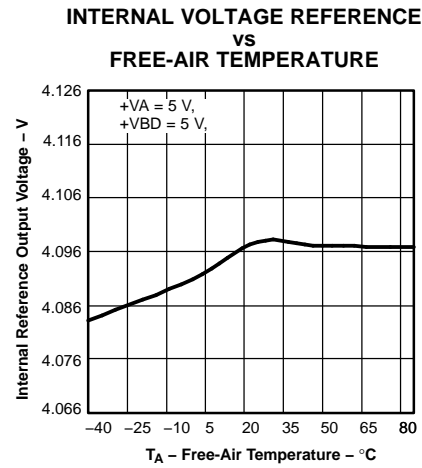


Figure 31.

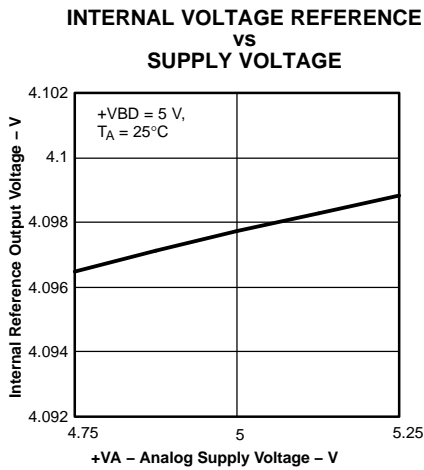


Figure 32.

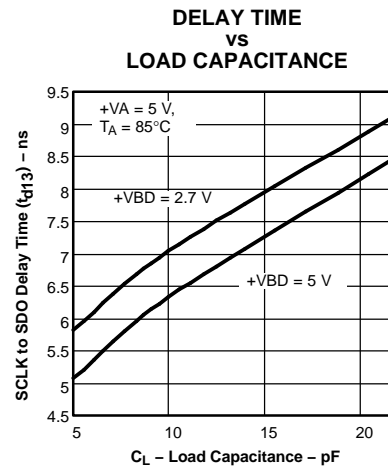


Figure 33.

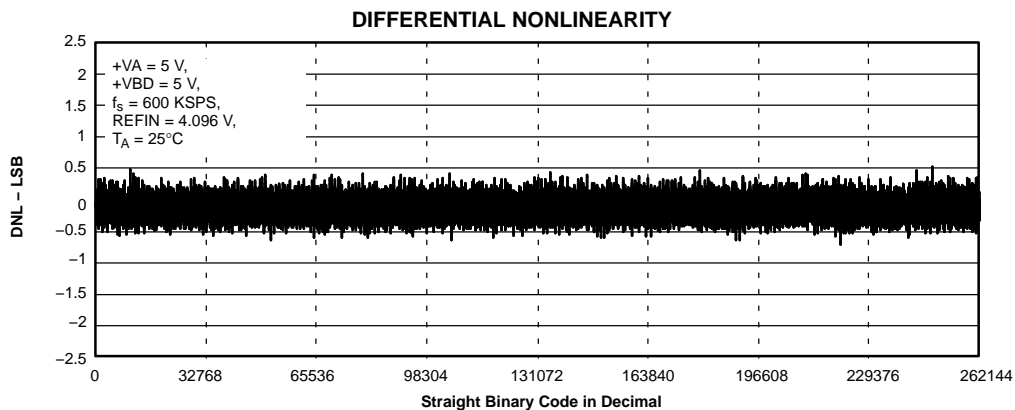


Figure 34.

TYPICAL CHARACTERISTICS (continued)

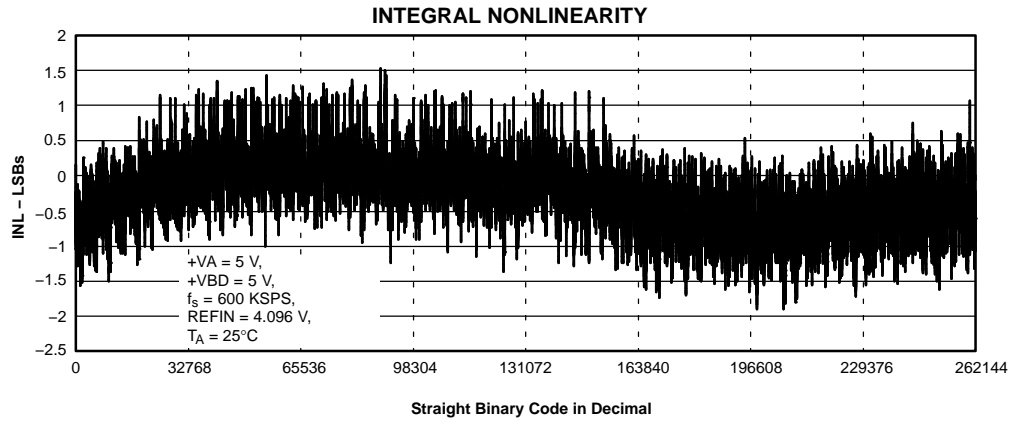


Figure 35.

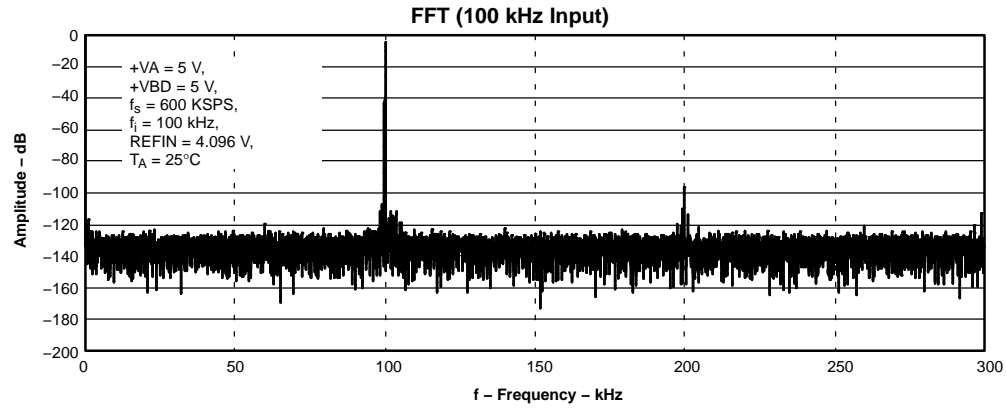


Figure 36.

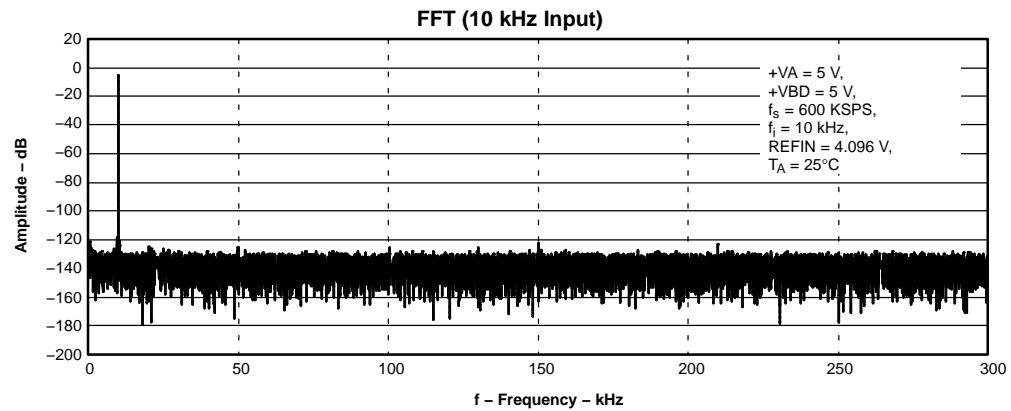
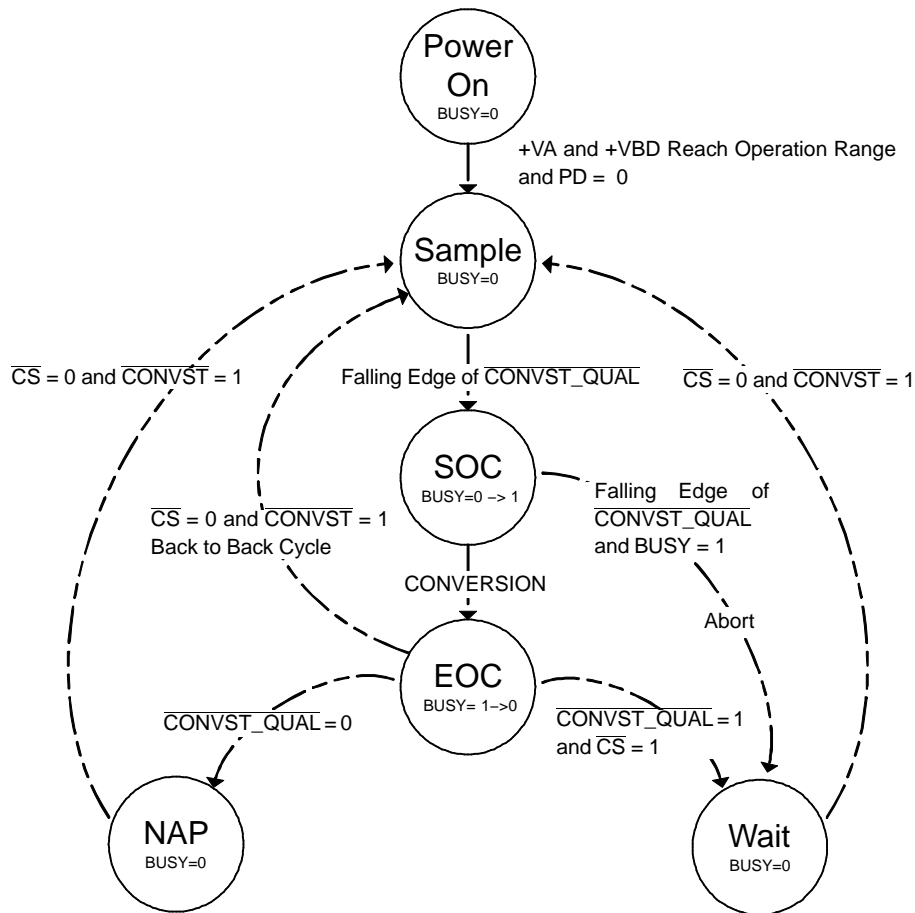


Figure 37.



A. EOC = End of conversion, SOC = Start of conversion, CONVST\_QUAL is CONVST latched by CS = 0, see Figure 39.

Figure 38. Device States and Ideal Transitions

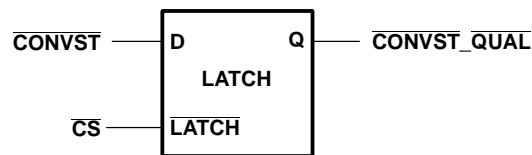


Figure 39. Relationship Between CONVST\_QUAL, CS, and CONVST

## TIMING DIAGRAMS

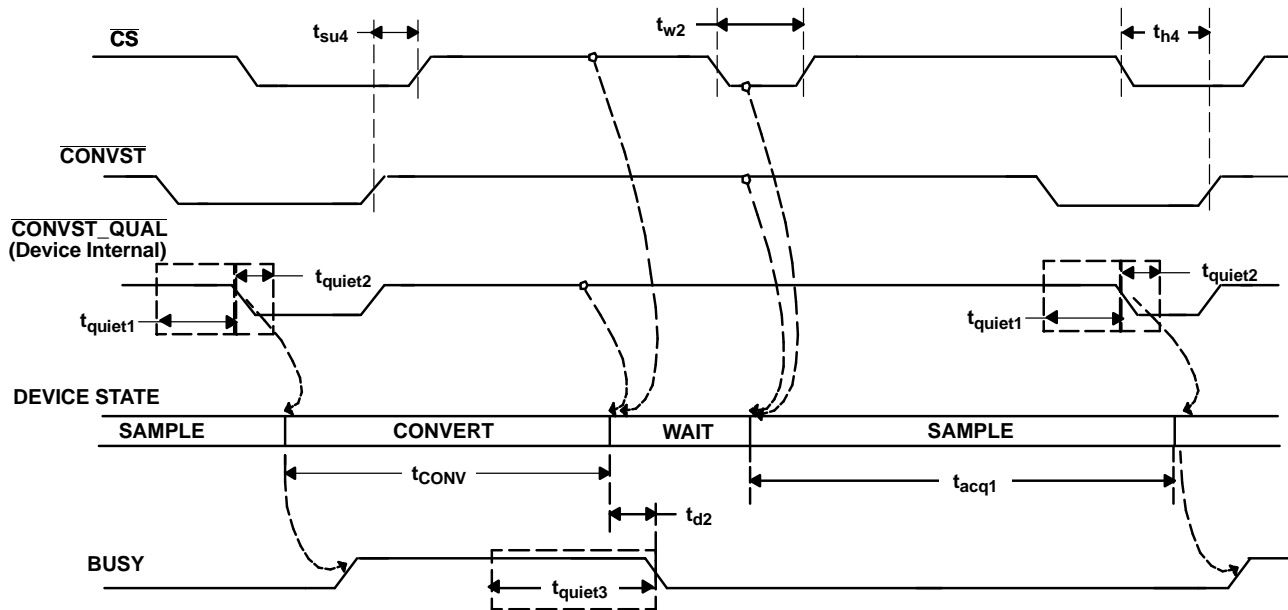
In the following descriptions, the signal CONVST\_QUAL represents CONVST latched by a low value on CS (see Figure 39).

To avoid performance degradation, there are three quiet zones to be observed ( $t_{quiet1}$  and  $t_{quiet2}$  are zones before and after the falling edge of CONVST\_QUAL while  $t_{quiet3}$  is a time zone before the falling edge of BUSY) where there should be no I/O activities. Interface control signals, including the serial clock should remain steady. Typical degradation in performance if these quiet zones are not observed is depicted in the specifications section.

To avoid data loss a read operation should not start around the BUSY falling edge. This is constrained by  $t_{su2}$ ,  $t_{su3}$ ,  $t_{h2}$ , and  $t_{h8}$ .

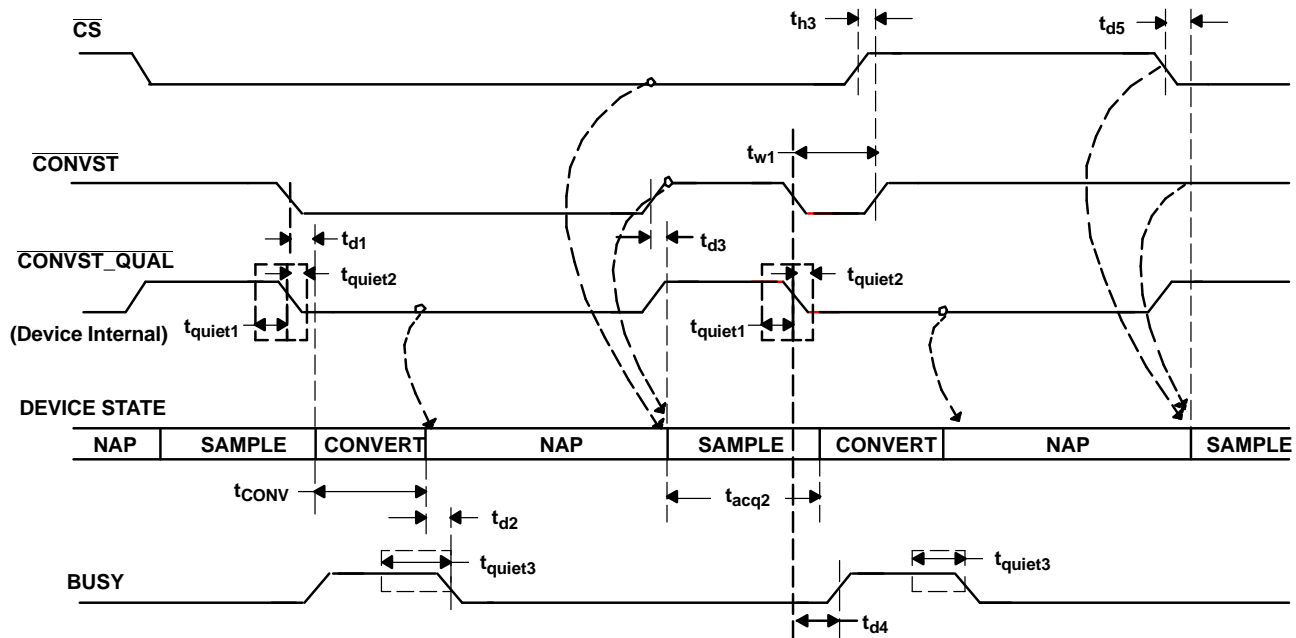


The device enters the wait phase at the end of the conversion if the sample start command is not given. This is shown in Figure 42.



**Figure 42. Convert and Sample with Wait**

If lower power dissipation is desired and throughput can be compromised, a nap state can be inserted in between cycles (as shown in Figure 43). The device enters a low power (3 mA) state called nap if the end of the conversion happens when `CONVST_QUAL` is low. The cost for using this special wait state is a longer sampling time ( $t_{acq2}$ ) plus the nap time.



**Figure 43. Convert and Sample with Nap**

4. Conversion abort command

An ongoing conversion can be aborted by using the conversion abort command. This is done by forcing another start of conversion (a valid  $\overline{\text{CONVST\_QUAL}}$  falling edge) onto an ongoing conversion as shown in Figure 44. The device enters the wait state after an aborted conversion. If the previous conversion was successfully aborted, the device output reads 0x3FC00 on SDO.

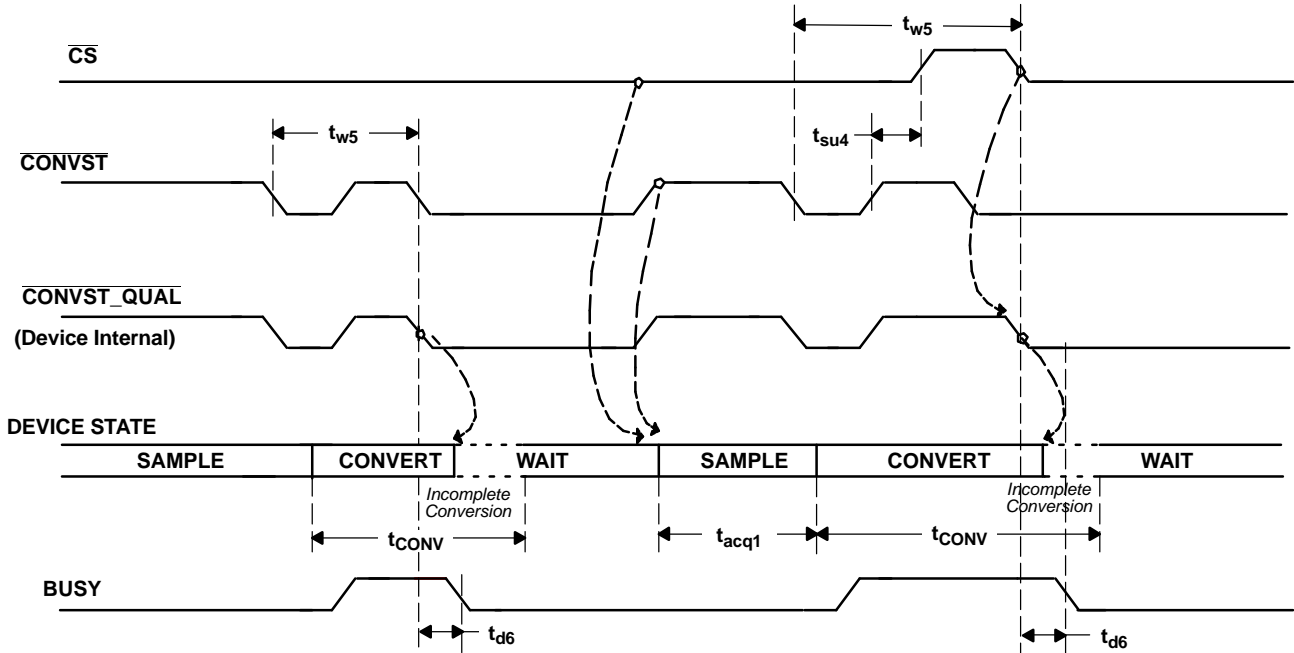


Figure 44. Conversion Abort

DATA READ OPERATION

Data read control is independent of conversion control. Data can be read either during conversion or during sampling. Data that is read during a conversion involves latency of one sample. The start of a new data frame around the fall of BUSY is constrained by  $t_{su2}$ ,  $t_{su3}$ ,  $t_{h2}$ , and  $t_{h8}$ .

1. SPI Interface:

A data read operation in SPI interface mode is shown in Figure 45.  $\overline{\text{FS}}$  must be tied high for operating in this mode. The MSB of the output data is available at the falling edge of  $\overline{\text{CS}}$ . MSB – 1 is shifted out at the first rising edge after the first falling edge of SCLK after  $\overline{\text{CS}}$  falling edge. Subsequent bits are shifted at the subsequent rising edges of SCLK. If another data frame is attempted (by pulling  $\overline{\text{CS}}$  high and subsequently low) during an active data frame, then the ongoing frame is aborted and a new frame is started.

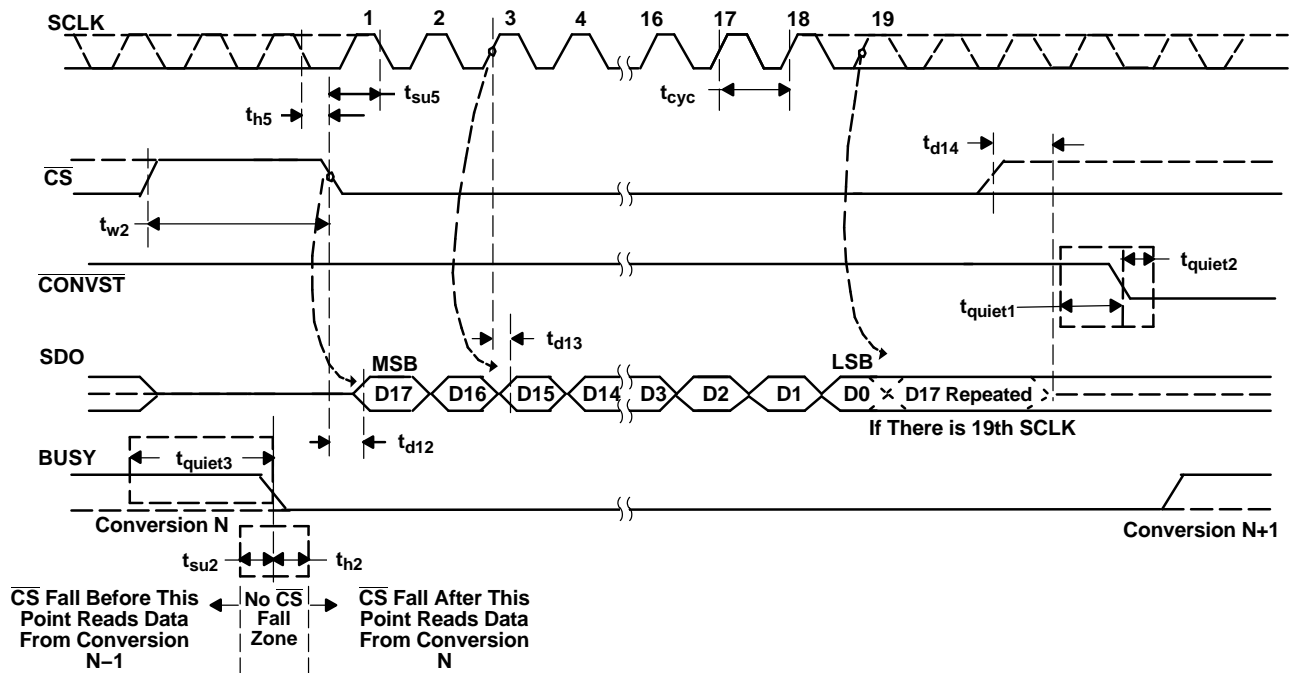


Figure 45. Read Frame Controlled via  $\overline{CS}$  (FS = 1)

If another data frame is attempted (by pulling  $\overline{CS}$  high and then low) during an active data frame, then the ongoing frame is aborted and a new frame is started.

2. Serial interface using FS:

A data read operation in this mode is shown in Figure 46 and Figure 47. The MSB of the output data is available at the rising edge of FS. MSB - 1 is shifted out at the first rising edge after the first falling edge of SCLK after the FS falling edge. Subsequent bits are shifted out at the subsequent rising edges of SCLK.

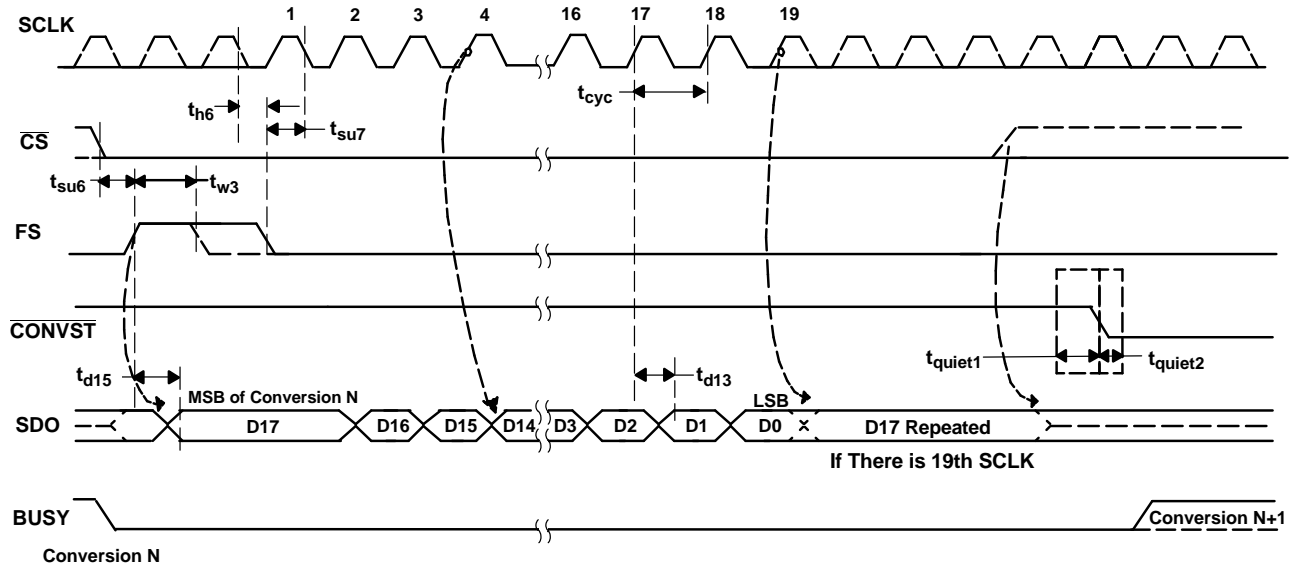


Figure 46. Read Frame Controlled via FS (FS is Low When BUSY Falls)

If FS is high when BUSY falls, the SDO is updated again with the new MSB when BUSY falls. This is shown in Figure 47.

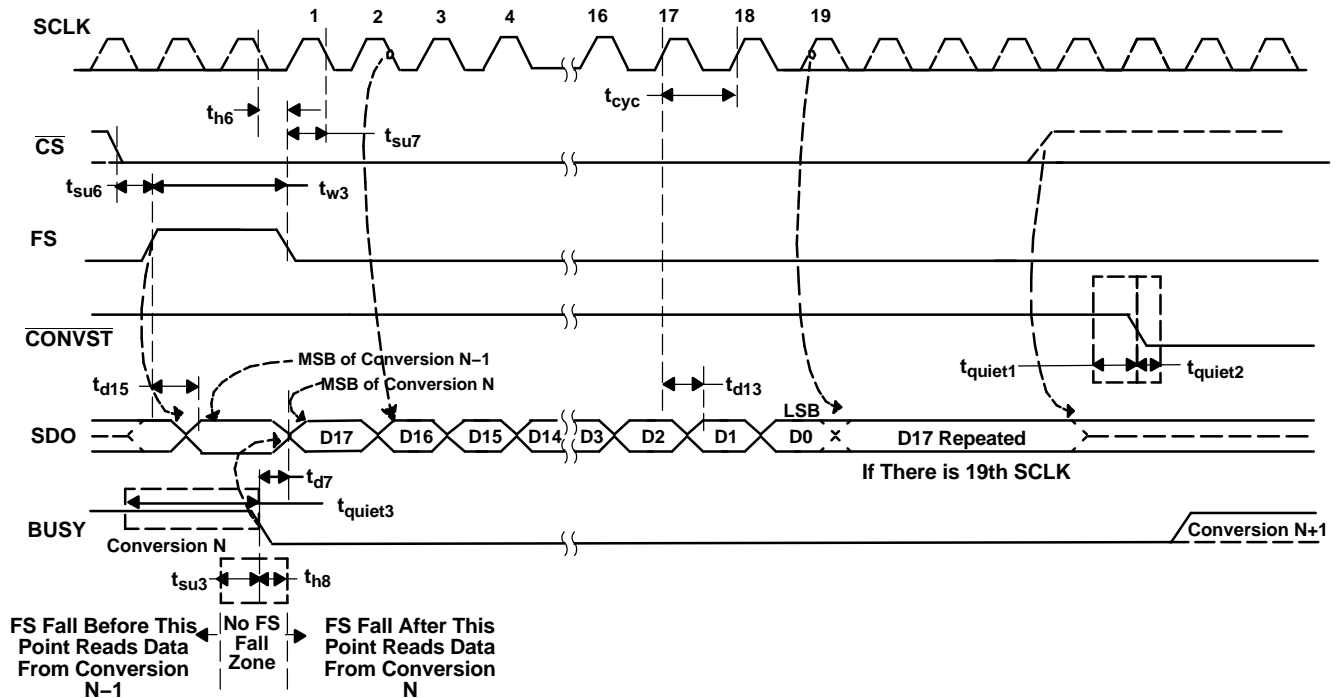


Figure 47. Read Frame Controlled via FS (FS is High When BUSY Falls)

If another data frame is attempted by pulling up FS during an active data frame, then the ongoing frame is aborted and a new frame is started.

### PRINCIPLES OF OPERATION

The ADS8380 is a high-speed successive approximation register (SAR) analog-to-digital converter (ADC). The architecture is based on charge redistribution, which inherently includes a sample/hold function.

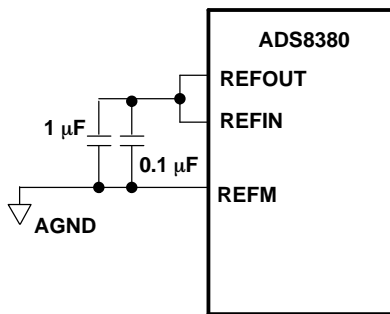
The device includes a built-in conversion clock, internal reference, and 40-MHz SPI compatible serial interface. The maximum conversion time is 1.16  $\mu$ s which is capable of sustaining a 600-kHz throughput.

The analog input is provided to the two input pins: +IN and -IN. When a conversion is initiated, the differential input on these pins is sampled on the internal capacitor array. While a conversion is in progress, both inputs are disconnected from any internal function.

### REFERENCE

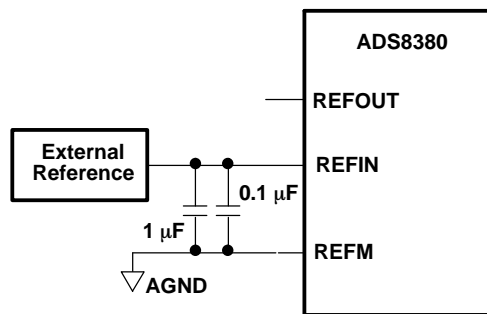
The ADS8380 has a built-in 4.096-V (nominal value) reference but can operate with an external reference also. When the internal reference is used, pin 9 (REFOUT) should be shorted to pin 8 (REFIN) and a 0.1- $\mu$ F decoupling capacitor and a 1- $\mu$ F storage capacitor must be connected between pin 8 (REFIN) and pin 7 (REFM) (see Figure 48). The internal reference of the converter is buffered.

**PRINCIPLES OF OPERATION (continued)**

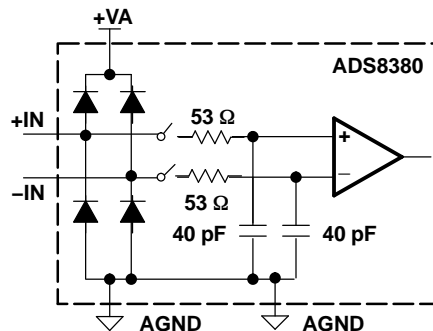


**Figure 48. ADS8380 Using Internal Reference**

The REFIN pin is also internally buffered. This eliminates the need to put a high bandwidth buffer on the board to drive the ADC reference and saves system area and power. When an external reference is used, the reference must be of low noise, which may be achieved by the addition of bypass capacitors from the REFIN pin to the REFM pin. See Figure 49 for operation of the ADS8380 with an external reference. REFM must be connected to the analog ground plane.



**Figure 49. ADS8380 Using External Reference**



**Figure 50. Simplified Analog Input**

**ANALOG INPUT**

When the converter enters hold mode, the voltage difference between the +IN and –IN inputs is captured on the internal capacitor array. The +IN input has a range of  $-0.2\text{ V}$  to  $(+V_{REF} + 0.2\text{ V})$ , whereas the –IN input has a range of  $-0.2\text{ V}$  to  $+0.2\text{ V}$ . The input span  $(+IN - (-IN))$  is limited from  $0\text{ V}$  to  $V_{REF}$ .

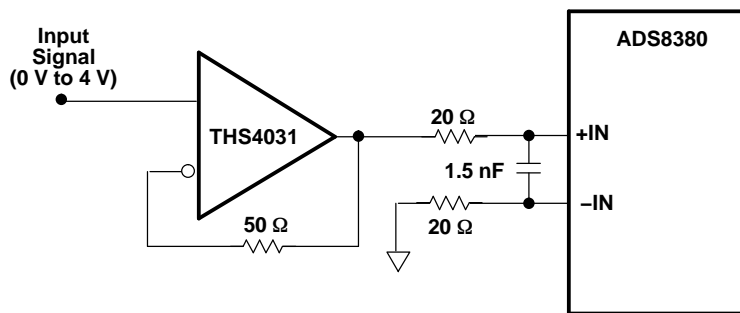
**PRINCIPLES OF OPERATION (continued)**

The input current on the analog inputs depends upon throughput and the frequency content of the analog input signals. Essentially, the current into the ADS8380 charges the internal capacitor array during the sampling (acquisition) time. After this capacitance has been fully charged, there is no further input current. The source of the analog input voltage must be able to charge the device sampling capacitance (40 pF each from +IN/-IN to AGND) to an 18-bit settling level within the sampling (acquisition) time of the device. When the converter goes into hold mode, the input resistance is greater than 1 GΩ.

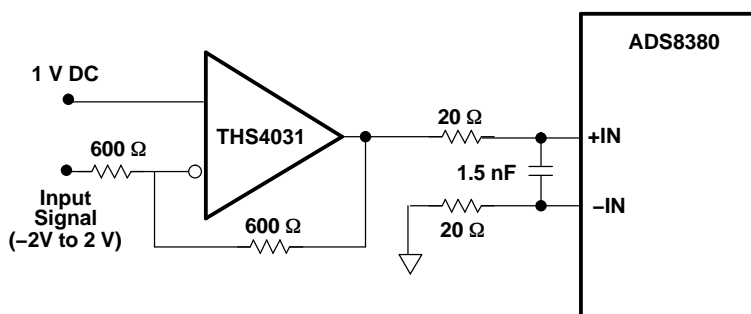
Care must be taken regarding the absolute analog input voltage. To maintain the linearity of the converter, the +IN, -IN inputs and the span (+IN - (-IN)) should be within the limits specified. Outside of these ranges, the converter's linearity may not meet specifications.

Care should be taken to ensure that the output impedance of the sources driving +IN and -IN inputs are matched. If this is not observed, the two inputs can have different settling times. This can result in offset error, gain error, and linearity error which vary with temperature and input voltage.

A typical input circuit using TI's THS4031 is shown in Figure 52. In the figure, input from a bipolar source is converted to a unipolar signal for the ADS8380. In the case where the source signal is in range for the ADS8380, the circuit in Figure 51 may be used. Most of the specified performance figure were measured using the circuit in Figure 51.



**Figure 51. Unipolar Input Drive Configuration**



**Figure 52. Bipolar Input Drive Configuration**

**DIGITAL INTERFACE**

**TIMING AND CONTROL**

Conversion and sampling are controlled by the  $\overline{\text{CONVST}}$  and  $\overline{\text{CS}}$  pins. See the timing diagrams for detailed information on timing signals and their requirements. The ADS8380 uses an internally generated clock to control the conversion rate and in turn the throughput of the converter. SCLK is used for reading converted data only. A clean and low jitter conversion start command is important for the performance of the converter. There is a minimal quiet zone requirement around the conversion start command as mentioned in the timing requirements table.

## DIGITAL INTERFACE (continued)

### READING DATA

The ADS8380 offers a high speed serial interface that is compatible with the SPI protocol. The device outputs data in either 2's complement format or straight binary format depending on the state of the  $\overline{SB}/2C$  pin. Refer to Table 1 for the ideal output codes.

**Table 1. Input Voltages and Ideal Output Codes**

DESCRIPTION	ANALOG VALUE +IN – (–IN)	DIGITAL OUTPUT (HEXADECIMAL)	
Full-scale range	$(+V_{REF})$	$\overline{SB}/2C$ Pin = 0	$\overline{SB}/2c$ Pin = 1
Least significant bit (LSB)	$(+V_{REF})/2^{18}$		
Full scale	$V_{REF} - 1 \text{ LSB}$	3FFFF	1FFFF
Mid scale	$(+V_{REF})/2$	20000	00000
Mid scale – 1 LSB	$(+V_{REF})/2 - 1 \text{ LSB}$	1FFFF	3FFFF
0	0	00000	20000

To avoid performance degradation due to the toggling of device buffers, read operation must not be performed in the specified quiet zones ( $t_{quiet1}$ ,  $t_{quiet2}$ , and  $t_{quiet3}$ ). Internal to the device, the previously converted data is updated with the new data near the fall of BUSY. Hence, the fall of  $\overline{CS}$  and the fall of FS around the fall of BUSY is constrained. This is specified by  $t_{su2}$ ,  $t_{su3}$ ,  $t_{h2}$ , and  $t_{h8}$  in the timing requirements table.

### POWER SAVING

The converter provides two power saving modes, full power down and nap. Refer to Table 2 for information on activation/deactivation and resumption time for both modes.

**Table 2. Power Save**

TYPE OF POWER DOWN	SDO	POWER CONSUMPTION	ACTIVATED BY	ACTIVATION TIME ( $t_{d16}$ )	RESUME POWER BY
Normal operation	Not 3 stated	22 mA	NA	NA	NA
Full power down (Int Ref, 1- $\mu$ F capacitor on REFOUT pin)	3 Stated ( $t_{d10}$ timing)	2 $\mu$ A	PD = 1	10 $\mu$ s	PD = 0
Full power down (Ext Ref, 1- $\mu$ F capacitor on REFOUT pin)	3 Stated ( $t_{d10}$ timing)	2 $\mu$ A	PD = 1	10 $\mu$ s	PD = 0
Nap power down	Not 3 stated	3 mA	At EOC and $\overline{CONVST\_QUAL} = 0$	200 ns	Sample Start command

### FULL POWER-DOWN MODE

Full power-down mode is activated by turning off the supply or by asserting PD to 1. See Figure 53 and Figure 54. The device can be resumed from full power down by either turning on the power supply or by de-asserting the PD pin. The first two conversions produce inaccurate results because during this period the device loads its trim values to ensure the specified accuracy.

If an internal reference is used (with a 1- $\mu$ F capacitor installed between the REFOUT and REFM pins), the total resume time ( $t_{d18}$ ) is 25 ms. After the first two conversions,  $t_{d17}$  (4 ms) is required for the trimmed internal reference voltage to settle to the specified accuracy. Only then the converted results match the specified accuracy.

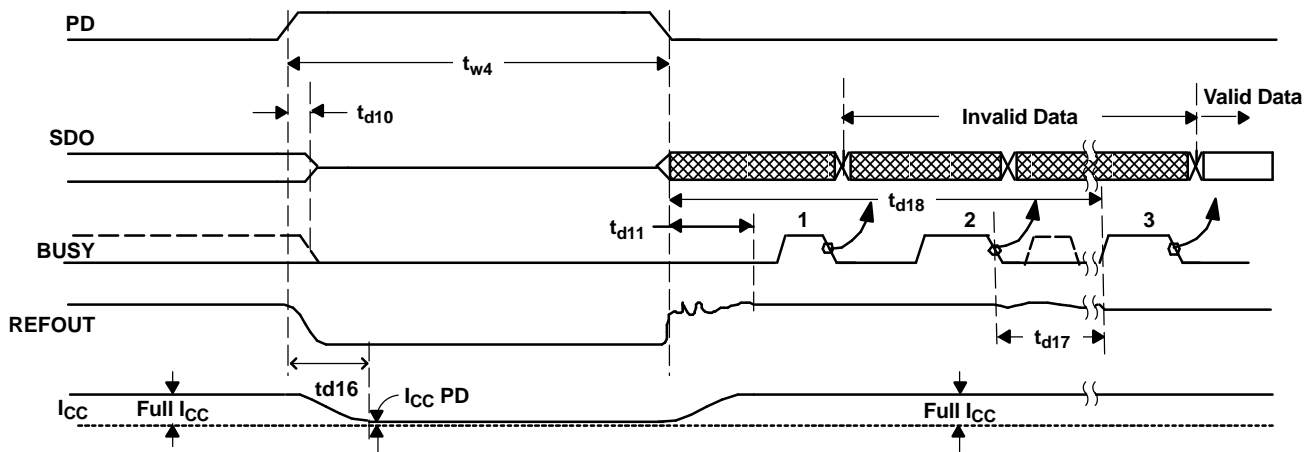


Figure 53. Device Full Power Down/Resume (Internal Reference Used)

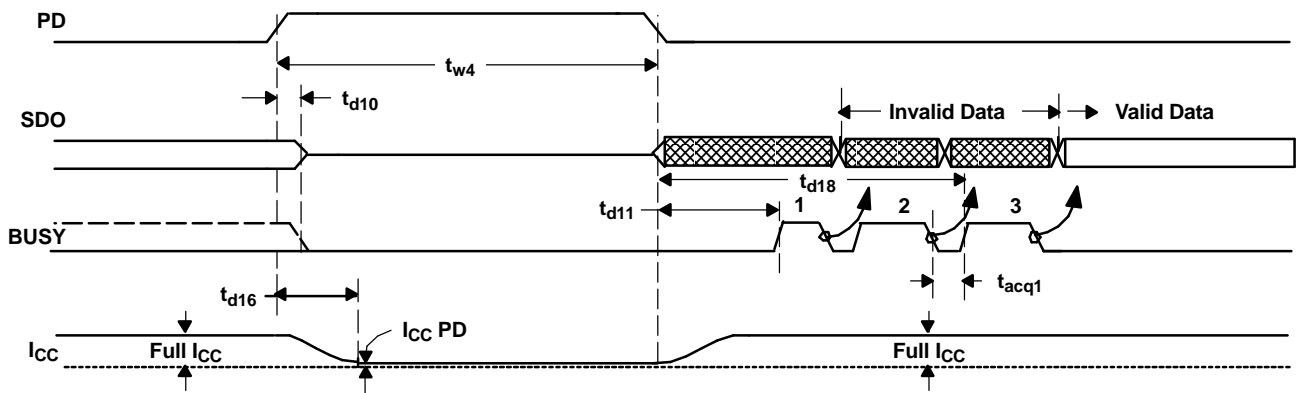


Figure 54. Device Full Power Down/Resume (External Reference Used)

## NAP MODE

Nap mode is automatically inserted at the end of a conversion if `CONVST_QUAL` is held low at EOC. The device can be operated in nap mode at the end of every conversion for saving power at lower throughputs. Another way to use this mode is to convert multiple times and then enter nap mode. The minimum sampling time after a nap state is  $t_{acq1} + t_{d18} = t_{acq2}$ .

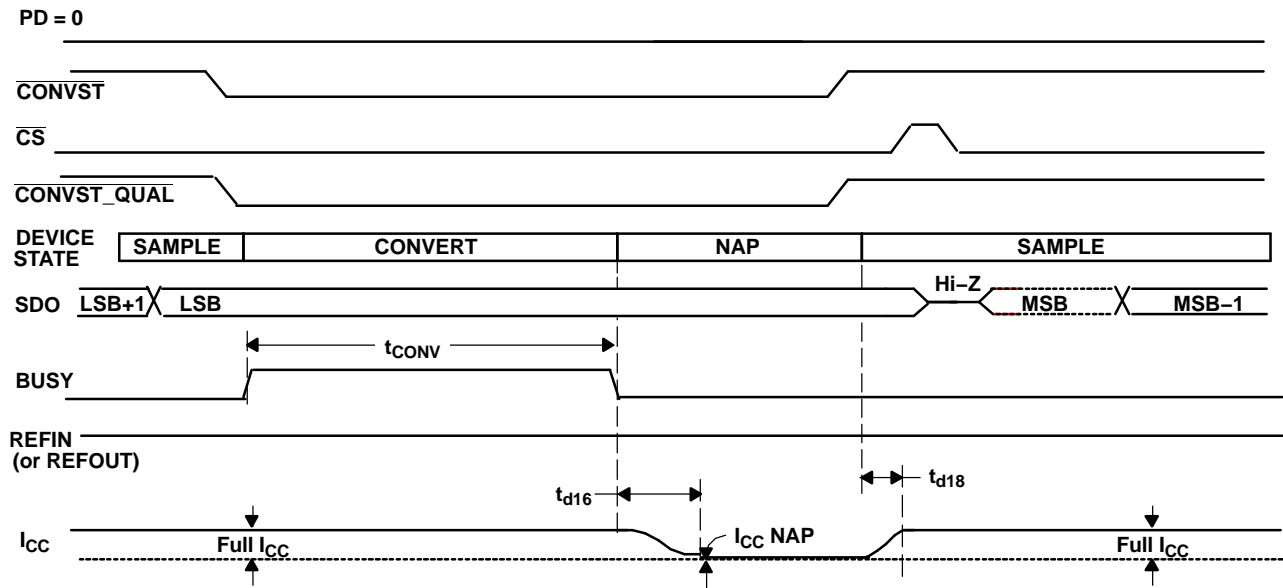


Figure 55. Device Nap Power Down/Resume

## LAYOUT

For optimum performance, care should be taken with the physical layout of the ADS8380 circuitry.

Since the ADS8380 offers single-supply operation, it is often used in close proximity with digital logic, microcontrollers, microprocessors, and digital signal processors. The more the digital logic in the design and the higher the switching speed, the greater the need for better layout and isolation of the critical analog signals from these switching digital signals.

The basic SAR architecture is sensitive to glitches or sudden changes on the power supply, reference, ground connections and digital inputs that occur just prior to the end of sampling and just prior to the latching of the analog comparator. Such glitches might originate from switching power supplies, nearby digital logic, or high power devices. Noise during the end of sampling and the latter half of the conversion must be kept to a minimum (the former half of the conversion is not very sensitive since the device uses a proprietary error correction algorithm to correct for the transient errors made here).

The degree of error in the digital output depends on the reference voltage, layout, and the exact timing and degree of the external event.

On average, the ADS8380 draws very little current from an external reference as the reference voltage is internally buffered. If the reference voltage is external, it must be ensured that the reference source can drive the bypass capacitor without oscillation. A 0.1- $\mu\text{F}$  bypass capacitor is recommended from pin 8 directly to pin 7 (REFM).

The AGND and BDGND pins should be connected to a clean ground point. In all cases, this should be the *analog* ground. Avoid connections that are too close to the grounding point of a microcontroller or digital signal processor. If required, run a ground trace directly from the converter to the power supply entry point. The ideal layout consists of an analog ground plane dedicated to the converter and associated analog circuitry.

As with the AGND connections, +VA should be connected to a +5-V power-supply plane or trace that is separate from the connection for digital logic until they are connected at the power entry point. Power to the ADS8380 should be clean and well bypassed. A 0.1- $\mu\text{F}$  ceramic bypass capacitor should be placed as close to the device as possible. See Table 3 for the placement of these capacitors. In addition, a 1- $\mu\text{F}$  capacitor is recommended. In some situations, additional bypassing may be required, such as a 100- $\mu\text{F}$  electrolytic capacitor or even a *Pi* filter made up of inductors and capacitors—all designed to essentially low-pass filter the +5-V supply, removing the high frequency noise.

**Table 3. Power Supply Decoupling Capacitor Placement**

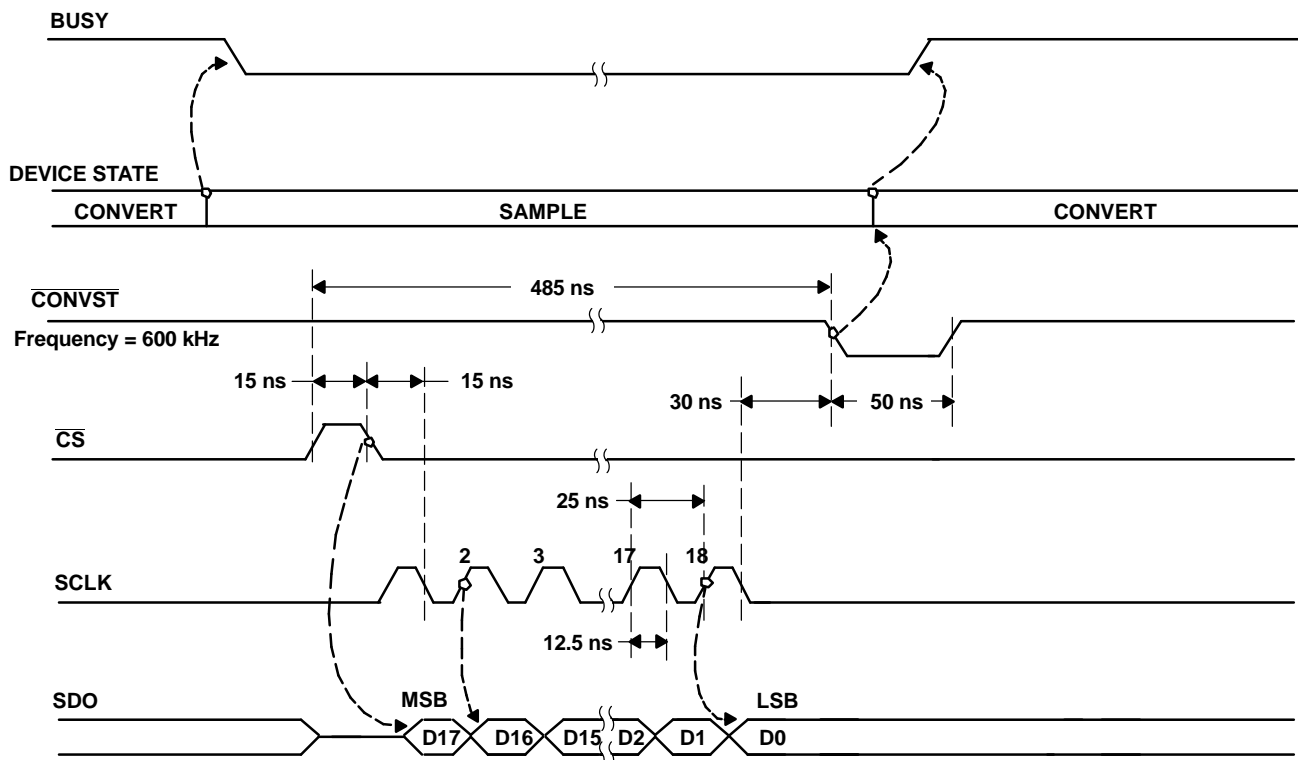
SUPPLY PINS	CONVERTER ANALOG SIDE	CONVERTER DIGITAL SIDE
Pair of pins requiring a shortest path to decoupling capacitors	(2,3); (5,6); (15,16); (17,18)	(20,21)
Pins requiring no decoupling	4, 14, 19	

When using the internal reference, ensure a shortest path from REFOUT (pin 9) to REFIN (pin 8) with the bypass capacitor directly between pins 8 and 7.

**APPLICATION INFORMATION**

**EXAMPLE DIGITAL STIMULUS**

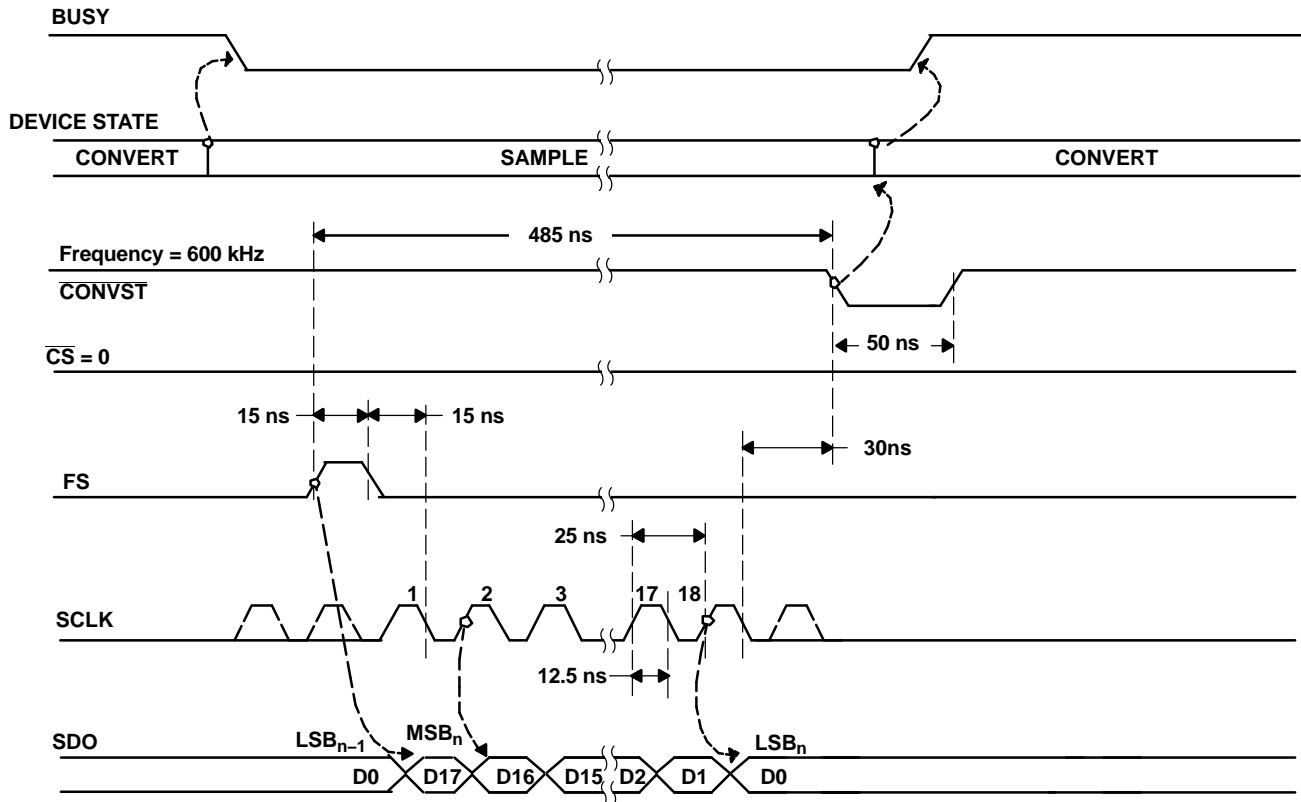
The use of the ADS8380 is very straightforward. The following timing diagram shows one example of how to achieve a 600-KSPS throughput using a SPI compatible serial interface.



**Figure 56. Example Stimulus in SPI Mode (FS =1), Back-To-Back Conversion that Achieves 600 KSPS**

**APPLICATION INFORMATION (continued)**

It is also possible to use the frame sync signal, FS. The following timing diagram shows how to achieve a 600-KSPS throughput using a modified serial interface with FS active.



**Figure 57. Example Stimulus in Serial Interface With FS Active, Back-To-Back Conversion that Achieves 600 KSPS**

## IMPORTANT NOTICE

Texas Instruments Incorporated and its subsidiaries (TI) reserve the right to make corrections, modifications, enhancements, improvements, and other changes to its products and services at any time and to discontinue any product or service without notice. Customers should obtain the latest relevant information before placing orders and should verify that such information is current and complete. All products are sold subject to TI's terms and conditions of sale supplied at the time of order acknowledgment.

TI warrants performance of its hardware products to the specifications applicable at the time of sale in accordance with TI's standard warranty. Testing and other quality control techniques are used to the extent TI deems necessary to support this warranty. Except where mandated by government requirements, testing of all parameters of each product is not necessarily performed.

TI assumes no liability for applications assistance or customer product design. Customers are responsible for their products and applications using TI components. To minimize the risks associated with customer products and applications, customers should provide adequate design and operating safeguards.

TI does not warrant or represent that any license, either express or implied, is granted under any TI patent right, copyright, mask work right, or other TI intellectual property right relating to any combination, machine, or process in which TI products or services are used. Information published by TI regarding third-party products or services does not constitute a license from TI to use such products or services or a warranty or endorsement thereof. Use of such information may require a license from a third party under the patents or other intellectual property of the third party, or a license from TI under the patents or other intellectual property of TI.

Reproduction of information in TI data books or data sheets is permissible only if reproduction is without alteration and is accompanied by all associated warranties, conditions, limitations, and notices. Reproduction of this information with alteration is an unfair and deceptive business practice. TI is not responsible or liable for such altered documentation.

Resale of TI products or services with statements different from or beyond the parameters stated by TI for that product or service voids all express and any implied warranties for the associated TI product or service and is an unfair and deceptive business practice. TI is not responsible or liable for any such statements.

Following are URLs where you can obtain information on other Texas Instruments products and application solutions:

<b>Products</b>		<b>Applications</b>	
Amplifiers	<a href="http://amplifier.ti.com">amplifier.ti.com</a>	Audio	<a href="http://www.ti.com/audio">www.ti.com/audio</a>
Data Converters	<a href="http://dataconverter.ti.com">dataconverter.ti.com</a>	Automotive	<a href="http://www.ti.com/automotive">www.ti.com/automotive</a>
DSP	<a href="http://dsp.ti.com">dsp.ti.com</a>	Broadband	<a href="http://www.ti.com/broadband">www.ti.com/broadband</a>
Interface	<a href="http://interface.ti.com">interface.ti.com</a>	Digital Control	<a href="http://www.ti.com/digitalcontrol">www.ti.com/digitalcontrol</a>
Logic	<a href="http://logic.ti.com">logic.ti.com</a>	Military	<a href="http://www.ti.com/military">www.ti.com/military</a>
Power Mgmt	<a href="http://power.ti.com">power.ti.com</a>	Optical Networking	<a href="http://www.ti.com/opticalnetwork">www.ti.com/opticalnetwork</a>
Microcontrollers	<a href="http://microcontroller.ti.com">microcontroller.ti.com</a>	Security	<a href="http://www.ti.com/security">www.ti.com/security</a>
		Telephony	<a href="http://www.ti.com/telephony">www.ti.com/telephony</a>
		Video & Imaging	<a href="http://www.ti.com/video">www.ti.com/video</a>
		Wireless	<a href="http://www.ti.com/wireless">www.ti.com/wireless</a>

Mailing Address: Texas Instruments  
Post Office Box 655303 Dallas, Texas 75265